



Advanced Steam Turbine Controls - Generator Drives

A Petrotech, Inc. White Paper

Petrotech. Inc.

EXPERIENCE • CAPABILITY • EXECUTION

Corporate Headquarters

151 Brookhollow Esplanade

New Orleans, LA 70123

Phone: (504) 620 – 6600

Fax: (504) 620 – 6601

www.petrotechinc.com

Company Overview

Petrotech Incorporated (Petrotech), headquartered in New Orleans, Louisiana has been providing advanced turbomachinery and process control systems for more than 40 years. With facilities in Houston, Texas and Suffolk, United Kingdom, Petrotech provides a full range of products and services for rotating machinery control and instrumentation. Our products include integrated control systems for gas and steam turbines, generators, compressors, pumps and the associated ancillary equipment. We also provide sophisticated process control solutions around the rotating machinery that complement or replace DCS based plant controls. Our turnkey services include engineering design (software and hardware), control panel manufacturing, site I&E services, commissioning and startup.

Within the energy sector, Petrotech has installed control system solutions for oil & gas, petrochemical and power generation plants. We help our customers increase reliability, improve efficiency and reduce downtime. Over our 40 years, we have developed a library of mature control products and applications for centrifugal and reciprocating compressors anti-surge and process control, as well as gas, hydro and steam turbines. These applications have logged millions of hours controlling, optimizing and protecting the operation of a variety of rotating machinery.

Regardless of where in the energy chain Petrotech operates, our approach remains the same. To deliver superior customer satisfaction, that builds upon our reputation as a leader in rotating machinery controls.

Abstract

In process plants, refineries and small power producing facilities, the three most common types of steam turbines include:

Straight Flow Turbines

In straight flow steam turbines, the steam is admitted through the steam control valve(s). The entire mass flowrate of steam flows through all of the turbine stages and exits after the last stage into a condenser in the case of a condensing steam turbine, or into an exhaust steam header in the case of a back pressure turbine.

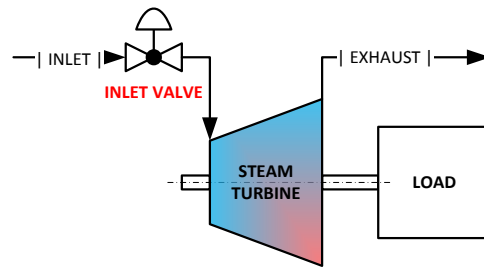

Figure 1 - Simple Steam Turbine

Single Extraction/Admission Turbines

In single extraction steam turbines, the steam is admitted through the steam control valve(s) and flows through the high pressure stages. An extraction control valve then splits the steam path into an extraction stream and a low pressure stream. The extraction stream exits the steam turbine to be used elsewhere in the facility for process purposes. The low pressure stream passes through the low pressure stages and into a condenser in the case of a condensing steam turbine, or into an exhaust steam header in the case of a back pressure turbine.

Admission turbines work similarly to extraction turbines, with the exception that additional low pressure steam is admitted to the low pressure stages of the turbine.

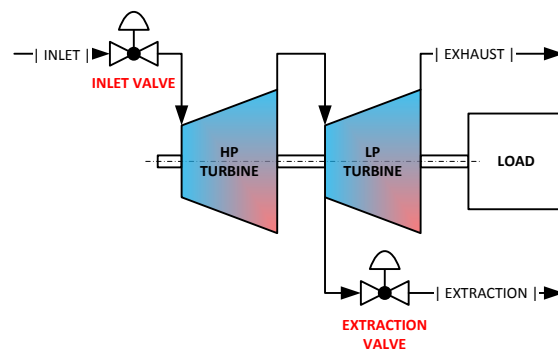

Figure 2 - Single Extraction Turbine

Double Extraction Turbines

Double extraction steam turbines operate similarly as single extraction steam turbines, except there are two extraction valves allowing for two extraction points for process steam.

Petrotech Steam Turbine Controller (STC)

The Petrotech STC manages the operation of the steam turbine from issuance of the start command all the way through the warmup to loaded operation. The STC provides a standard foundation to integrate steam turbine control systems into either a mechanical or electrical drive application and provides the appropriate sequence interfaces to the auxiliary systems, such as lube oil gland seals.

The starting/warmup control sequence is a highly configurable program, which provides the ability to tailor the warmup and start sequence to meet virtually any manufacturer's warmup and slow roll requirements for cold, warm and hot start sequences. Once the steam turbine is at load speed, the load speed governor assumes control of the steam valve to manage the turbine output.

Additional controls also manage the extraction and admission requirements for extraction/admission of steam turbines to comply with the OEMs extraction and admission limits.

Main Steam Valve Control

Starting/Warmup/Override Speed Control

The starting/warmup control logic governs the steam turbine's speed setpoint through the warmup cycle, up to the loading speed. Once the start command is issued, the controller determines the warmup mode depending on how long the steam turbine has been shutdown. The warmup mode, selected by the STC, is based on the duration of the last shutdown and has three configurable warmup modes (Cold Start, Warm Start and Hot Start) each with configurable warmup/rampup settings. Configurable parameters are easily adjusted to make it possible to configure virtually any desirable warmup sequence. Each starting/warmup sequence has 10 configurable speed setpoints and speed setpoint ramp rates. The speed setpoints are configured for the holding setpoint with a setpoint dwell timer. In the case where less than 10 setpoints are necessary (e.g., Hot Start), the dwell timers are set to zero. The 9th and 10th speed setpoints are always configured as the minimum governor speed setpoint and the maximum governor speed setpoint respectively.

Cold Start

When the shutdown time exceeds the cold start time limit, the starting/warmup logic brings the steam turbine to loading via the configured cold start warmup speed plateaus and ramp rate plateaus.

Warm Start

When the shutdown time exceeds the hot start time limit but is less than the cold start time limit, the starting/warmup logic brings the steam turbine to loading via the configured warm start warmup speed plateaus and ramp rate plateaus.

Hot Start

When the shutdown time is less than the warm start time limit, the starting/warmup logic brings the steam turbine to loading via the configured hot start warmup speed plateaus and ramp rate plateaus.

Critical Speed Avoidance

In all start modes the logic includes configurable parameters to ramp the steam turbine through critical speeds at faster than normal ramp rates between the warmup plateaus when required.

Speed Override Controller

After the issuance of the load command, the speed override controller setpoint ramps up to the maximum governor speed setpoint. For the duration of loaded operation the speed override controller acts as a maximum governor controller.

Steam Inlet/Exit Pressure Controllers

The steam inlet pressure controller will govern the steam turbine speed in the event of reduced steam availability. As inlet pressure decreases the steam inlet pressure will trim the steam turbine demand signal in an effort to maintain the minimum safe steam pressure.

Conversely, the steam exit pressure controller will govern the steam turbine speed in the event of excessive exit steam pressure. As exit pressure increases, the steam inlet pressure will trim the steam turbine demand signal in an effort to maintain the minimum safe steam pressure.

Use of either steam pressure controller is optional and the function of either on can be enabled/disabled via configurable parameters.

Speed Load Controller

In electrical drive applications the operation of the speed load controller depends on whether the generator unit is synchronized to an electrical grid (droop mode) or operating in island mode (isochronous mode).

Droop Mode

In droop mode (utility tie breaker closed), speed regulation is not required because the frequency of the grid dictates the generator speed. Thus, the speed load controller becomes a load controller only.

In start-up sequences where the steam turbine driven generator must be synchronized to an existing grid, the starting/warmup control will bring the steam turbine to the generator synchronizing (load) speed. The automatic voltage regulation equipment (AVR) will excite the generator field to establish the appropriate voltage, and in conjunction, the synchronizing equipment will slowly ramp the speed load controller until the generator frequency synchronizes with the electrical grid frequency. Once synchronization is complete, the generator breaker is closed connecting the generator load to the electrical grid.

Once the generator load breaker is closed, the speed load controller will automatically begin a controlled load ramp from 0 MW to load MW setting dictated from the Human Machine Interface (HMI) input or process controller demand signal. This allows gradual loading of the unit. If at any time during the loading sequence, the steam inlet pressure drops below the steam pressure controller setpoint, the steam pressure controller will limit the unit loading until steam pressure recovers sufficiently to add more load to the generator. If required, the steam exhaust pressure controller works in a similar way to control steam discharge pressure.

Droop to Isochronous Transitions

The position of the utility tie breaker dictates the presence of droop or isochronous. Therefore, if the utility tie breaker opens at any time during loaded operation, the controls must transition the generator speed load controller to a speed or frequency controller. Petrotech's tightly integrated mode transition logic transitions the operation to the generator isochronous mode in a single controller scan.

Isochronous Mode

In isochronous mode, the controller will assume the current load of the entire plant and overrides the response of the MW and steam pressure controllers. The priority here is frequency (i.e., speed) control.

In start-up sequences where the steam turbine driven generator must operate in isochronous mode, the starting/warmup control will bring the steam turbine to the generator synchronizing (load) speed. The automatic voltage regulation equipment (AVR) will excite the generator field to establish the appropriate voltage and the synchronizing equipment will slowly ramp the speed load controller to the generator frequency setpoint. From here plant loads can be brought online as required.

Isochronous speed control is different from the load based droop control. In Isochronous mode the speed load controller operates as a full proportional-integral-derivative (PID) control loop. Full PID functionality provides Petrotech engineers the ability to configure the speed load controller to respond without frequency upset to large swings in the plant load whenever large motors or fans are started and stopped as a function of everyday operations.

Isochronous to Droop Transitions

While operating in isochronous mode, transitions back to droop mode occur in a single controller scan as well. When the generator load is synchronized with the electrical grid, the instantaneous plant load measured from the last isochronous scan becomes droop speed load controller setpoint and the controller will begin a controlled load ramp to the load MW setting dictated from the HMI input or process controller demand signal.

Main Steam Valve Auto-Manual Station

The main steam valve Auto-Manual station provides the means to override automatic speed response of the steam inlet/exit pressure and load speed controllers. The exception is the speed override controller. The speed override controller is always the last low selected controller in the logic low signal selection (LSS) in order to prevent unit overspeed conditions.

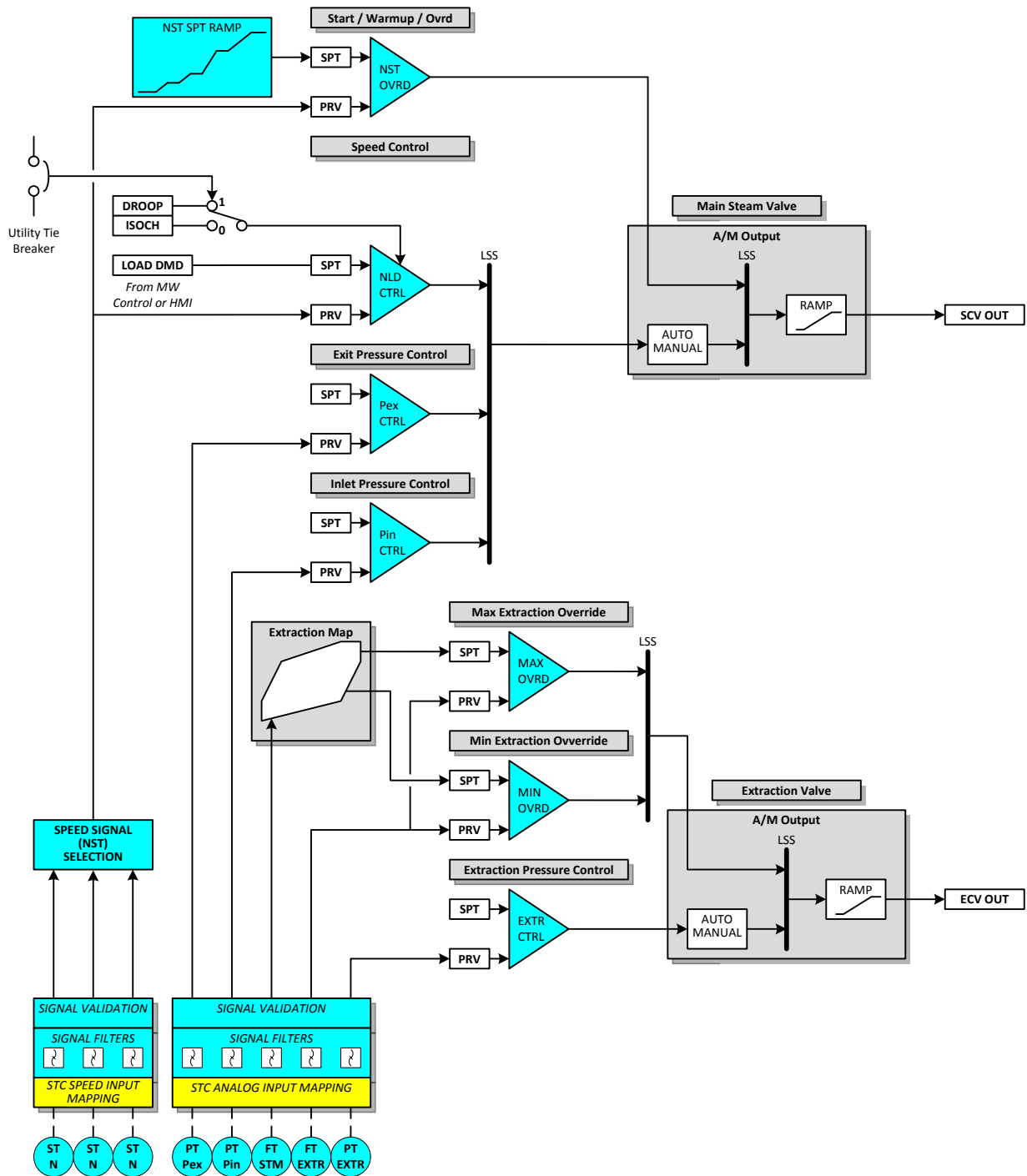

Figure 3 - Single Extraction Steam Turbine Controller for Generator Drive

Steam Extraction/Admission Control

The Steam Extraction Map defines the extraction operating range for extraction turbines as a function of inlet steam admitted to the steam turbine through the main steam valve. The extraction map defines the steam extraction boundaries (i.e., minimum extraction flowrate and maximum extraction flowrate).

The minimum extraction and maximum extraction flowrates determined via the operating conditions and extraction map will actively override the extraction pressure if conditions dictate.

Extraction/Admission, Minimum/Maximum Override Controllers

The extraction override controllers prevent the automatic extraction controller or the manual operation of the extraction control valve from exceeding the specified extraction/admission limits for the steam turbine. Using the main steam input and the load on the steam turbine, the extraction override controllers constantly update their respective minimum and maximum limits (i.e., setpoints) and when the extraction capacity approaches these limits the controllers override to prevent the extraction capacity from exceeding the limits.

Automatic Extraction/Admission Controller

Under normal conditions, the automatic extraction controller regulates the admission/extraction capacity to the user provided setpoint.

Extraction Valve Auto-Manual Station

The extraction valve Auto-Manual station provides the means to override the automatic response of the extraction pressure controller. The exceptions are the minimum and maximum extraction override controllers. The extraction override controllers are always the last low selected controllers in the logic low signal selection (LSS) in order to prevent too little or excessive extraction for the current operating conditions.

Conclusion

Petrotech's steam turbine control systems can be deployed in a variety of hardware platforms, to accommodate application requirements and user standardization preferences. The core STC application is

IEC 6-1131 compliant, thus simplifying the cross hardware platform compatibility. And when Petrotech is selected to perform the entire application scope, our engineers can fully leverage decoupling strategies between other integrated control systems.

In addition to a fully integrated system, Petrotech's STC is deployed in stand-alone applications where only the core steam control application is required. The STC application includes the following features:

- Starting/Warmup/Override Speed Control.
- Multiple and configurable starting and warmup calibration parameters to accommodate cold, warm and hot start requirements.
- Calibration parameters to customize critical speed avoidance strategies.
- Calibration parameters to customize the starting ramp rates.
- Automatic synchronizing with electrical grid on breaker closure.
- MW and Steam Supply Pressure control low selected to provide the droop control setpoint.
- Isochronous Controls when operating in island mode disconnected from the grid.
- Bumpless switchover between isochronous and droop based on the utility tie breaker input status.
- Pressure or Flowrate based Extraction Control.
- Extraction Minimum/Maximum Override Control.
- Manual override of automatic control response of both the main steam inlet valve and extraction control valve. Each with "Safe" manual features to protect against overspeed and violation of extraction limits.



Produced in the USA by Petrotech Incorporated. Copyright 2015

This document is Petrotech, Inc. copyrighted intellectual property and may be changed at any time without notice. All rights reserved.