

GE LM6000® GAS TURBINE GENERATOR DRIVE APPLICATION CONTROL PACKAGE

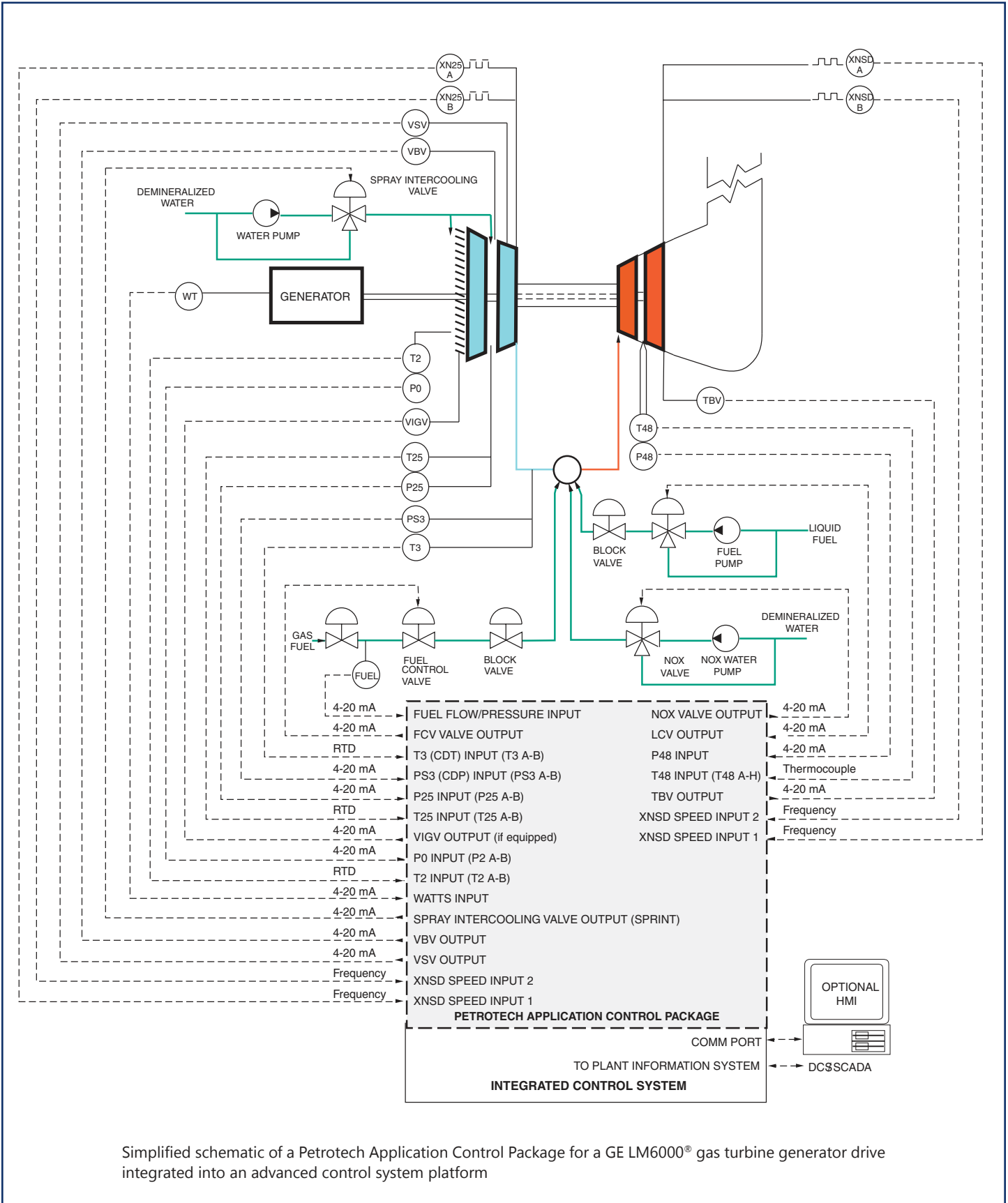

FEBRUARY 2016



Simplified schematic of a Petrotech Application Control Package for a GE LM6000® gas turbine generator drive integrated into an advanced control system platform



APPLICATION

The Petrotech GE LM6000® Application Control Package replaces the OEM obsolete proprietary control packages with a modern, reliable Petrotech Application Control Package which runs on an advanced industrial control system. The Application Control Package for the gas turbine generator set provides all control functions required for the reliable and safe operation of the equipment including fuel control, variable geometry control, sequencing, alarming, etc. It also provides spray intercooling water injection (SPRINT) control for power augmentation or NOx reduction, and dual fuel control for start-up and normal operations as well as for fuel changeover.

ADVANTAGES

- **Integrated control capability:**

Turbine fuel control and sequencing/protection are integrated into a single platform. This eliminates the need for additional hardware and communication links, thereby providing a less complicated, more cost-effective solution.

- **Open architecture system:**

Application Control Package's portability allows customer choice of platform, reducing need for additional spare parts and training expenses.

- **Fault tolerant:**

Application Control Package is available on fault tolerant controllers for critical control applications.

- **Standard industrial components:**

Non-proprietary, commonly available parts are less costly and more easily serviced by customer's on-site personnel. Much longer time to obsolescence than proprietary systems.

- **Reliability:**

ALL control functions are performed by tested and proven industrial control equipment.

- **Simplified interface to DCS or SCADA:**

Communication tasks are handled with a separate, dedicated module in the PLC, increasing data rate and simplifying network installation.

- **Non-proprietary interfaces:**

Interfaces in the form of 4-20 mA, RTD, frequency, thermo-couple, and dry contact I/O allow simple integration into existing control equipment, making very low-cost partial control upgrades simple and practical.

- **Improved fuel regulation:**

Fast loop sampling rate, combined with modern digital control techniques improve steady-state setpoint control, and reduce overshoot during transients.

- **Improved start-up reliability:**

Special "lean lightoff" procedure ignites all burners with essentially 100% reliability, and with greatly reduced thermal stress.

- **Improved exhaust temperature monitoring and control:**

Advanced statistical algorithms detect turbine hot/cold spots and automatically reject failed thermocouples.

- **Fail-safe features:**

Redundant overspeeds; open/short monitoring of Analog inputs and thermocouples; readback monitoring of outputs, and special self-check features improve safety.

- **Improved operator information with optional HMI:**

Industrial human-machine interface graphically displays such as start-up sequencing, speeds, temperatures, operating points, and alarm/shutdown status. Data logging and trending can be used as part of a preventative maintenance program. Alternatively, existing HMI can be reused to reduce initial cost and maintain common operator interface.

- **Simple installation:**

A dimensionally identical replacement of the control panel or control panels subplates is possible, saving substantial architectural and installation cost. Control panels can be installed one at a time allowing other units to continue operating.

- **Flexibility:**

The Application Control Package can accommodate many different control strategies based on the customer's need and budget.

SCOPE OF SUPPLY

The Application Control Package for GE LM6000 gas turbine generator drive system, includes:

Analog inputs, 4-20 mA:

- P0 Inlet Ambient Air Pressure
- P2 LPC Inlet pressure (with VIGVs)
- P25 HPC Inlet Pressure
- PS3 HPC Discharge Pressure (CDP)
- P48 Thrust Balance Pressure
- Gas Fuel Supply Pressure
- Gas Fuel Valve Position Feedback
- Generator Megawatts
- Liquid Fuel Pump Discharge Pressure (if applicable)
- Liquid Fuel Valve Position Feedback (if applicable)
- NOx Water Injection Valve Position Feedback
- PTB Thrust Balance Pressure
- Spray Intercooling Water Pressure (if applicable)
- Spray Intercooling Water Flow (if applicable)
- Spray Intercooling Air Pressure (if applicable)
- Turbine Flame Detector
- Variable Inlet Guide Vanes (VIGV) Position Feedback (if applicable)
- Variable Bleed Valves (VBV) Position Feedback
- Variable Stator Vanes (VSV) Position Feedback
- Variable Thrust Balance Valve (TBV) Position Feedback

Analog inputs, frequency:

- Redundant XN25 HPC Speed
- Redundant XNSD LPT Drive Shaft Speed

Analog Thermocouple inputs, mV:

- T3 HPC Discharge Temperature
- T48 LPT Inlet Temperature

Analog inputs, RTD:

- T2 LPC Inlet Temperature RTD
- T25 HPC Inlet Temperature RTD
- Gas Fuel Supply RTD
- Liquid Fuel Manifold RTD (if applicable)
- Liquid Fuel Supply RTD (if applicable)
- Spray Intercooling Water RTD (if applicable)
- Spray Intercooling Air (if applicable)



SCOPE OF SUPPLY - Continued

Analog outputs, 4-20 mA:

- Gas Fuel Metering Valve Position Setpoint
- Liquid Fuel Metering Valve Position Setpoint (if applicable)
- NOx Water Injection Metering Valve Position Setpoint
- Spray Intercooling Water Flow Control Valve Setpoint (if applicable)
- Variable Inlet Guide Vanes (VIGV) Position Setpoint (if applicable)
- Variable Bleed Valves (VBV) Position Setpoint
- Variable Stator Vanes (VSV) Position Setpoint
- Variable Thrust Balance Valve (TBV) Position Setpoint

Operating states:

- Firing
- Warm-up
- Accelerate
- Synchronize
- Load

Status, alarms, and shutdowns:

- Fault
- XN25 overspeed alarm
- XN25 underspeed alarm
- XN25 overspeed shutdown
- XNSD overspeed alarm
- XNSD underspeed alarm
- XNSD overspeed shutdown
- High T48 alarm
- High T48 shutdown
- Low T48 shutdown
- Rejected thermocouple
- Too few thermocouples shutdown
- Thermocouple spread alarm
- Thermocouple spread shutdown
- High Fuel Gas Pressure
- Gas Fuel Valve Position Error
- Liquid Fuel Valve Position Error
- NOx Water Injection Valve Position Error
- VBV Position Error
- VSV Position Error
- VIGV Position Error (if applicable)
- TBV Position Error
- Low Spray Intercooling Air Pressure (if applicable)
- Spray Intercooling Water Pressure (if applicable)
- Transmitter failure alarms
- Transmitter failure shutdowns

Controllers/Special Features

The Petrotech GE LM6000 Gas Turbine Application Control Package typically includes:

- Light off
- Startup ramp
- XNSD control with Droop and Isochronous modes
- XNSD acceleration control
- XN25 control
- XN25 acceleration control
- Pressure Compressor Discharge Pressure (PS3) Control
- Pressure Compressor Discharge Temperature (T3) Control
- Fuel Flow Limit Scheduling
- Base, Peak, and Peak Reserve capability
- Fast Start and Fast Load capability
- Combustion monitoring with:
 - ΔT and thermocouple spread alarm and shutdown (hot and cold sides)
 - Failed thermocouple detection and automatic rejection
 - Combustion monitoring graphics integrated into the HMI package
- Variable Inlet Guide Vane (VIGV) Control (if equipped)
- Variable Bypass Flow (VBV) Control
- Variable Stator Vanes Position (VSV) Control
- Thrust Balance Valve (TBV) Control
- NOx Water Injection Control
- Spray Intercooling Water Injection (SPRINT) Control
- Load control
- Stopping Modes:
 - Fast-Stop Lockout without monitoring (FSLO)
 - Fast-Stop with Monitoring (FSWM)
 - Cooldown Lockout (CDLO/NORMAL)
 - Slow Decel to Minimum Load (SML)
 - Step Decel to Idle (SDTI)
- Dual fuel capability with bumpless on-line transfer

OPTIONS FOR COMPLETE CONTROL SYSTEM UPGRADE

- Gas turbine sequencing and protection discrete logic
- Generator sequencing and protection discrete logic
- Communication interface to DCS or SCADA
- Controller hardware
- Human machine interface unit with licensed software package
- Complete custom engineered control panel, factory tested and ready to install
- Fuel valve system upgrade
- Thermocouple upgrade
- Flame sensor upgrade
- Vibration system upgrade
- Installation and commissioning
- Training

Petrotech, Inc.
151 Brookhollow Esplanade
New Orleans, Louisiana 70123
USA

Phone: +1 (504) 620-6600
Fax: +1 (504) 620-6601
Email: info@petrotechinc.com
Website: www.petrotechinc.com