

GE FRAME 3® GAS TURBINE GENERATOR DRIVE APPLICATION CONTROL PACKAGE

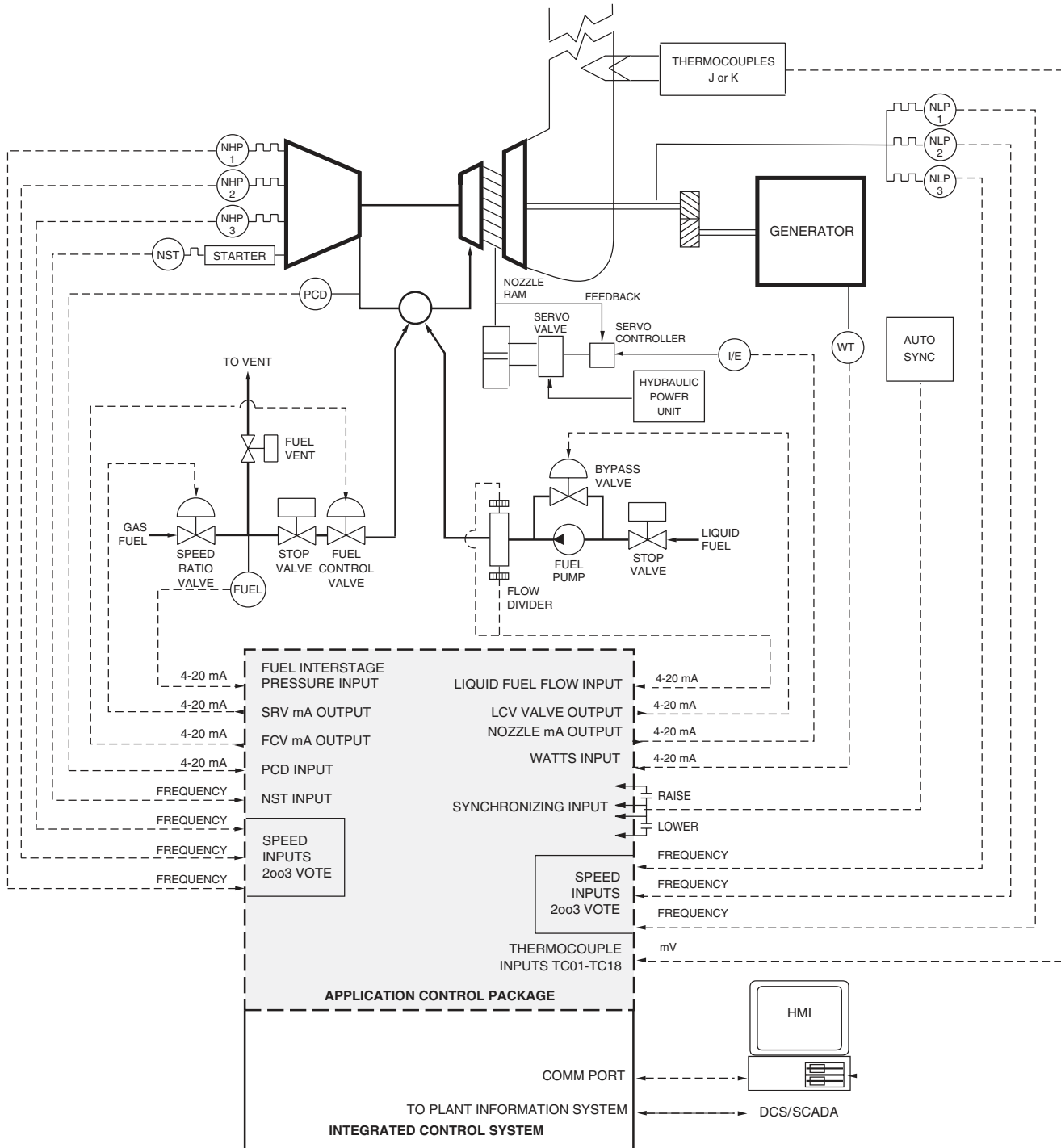

FEBRUARY 2016



Simplified schematic showing a Petrotech GE Frame 3® gas turbine generator drive application control package integrated into an advanced PLC-based control system. Shown with dual fuel system.



APPLICATION

The GE Frame 3® application control package replaces older mechanical/hydraulic/electronic/pneumatic GE Frame 3® fuel regulators with a modern, reliable application control package which runs on an advanced PLC-based system. The control package for the gas turbine provides fuel control, speed ratio control and nozzle control based on speed and temperature.

ADVANTAGES

- **Hardware independent system:**
Application control package's portability allows customer choice of PLC platform, reducing need for additional spare parts and training expenses. Available PLCs include General Electric, Siemens/TI, Allen-Bradley and Modicon.
- **Fault tolerant:**
The control package is available on tolerant controllers for critical control applications.
- **Simplified interface to DCS or SCADA:**
Communication tasks are handled with a separate, dedicated module in the PLC, increasing data rate and simplifying network installation.
- **Improved fuel regulation:**
Fast loop sampling rate, combined with modern digital control techniques, improves steady-state setpoint control, and reduces overshoot during transients.
- **Improved start-up reliability:**
Special "lean lightoff" procedure ignites all burners with essentially 100% reliability, and with greatly reduced thermal stress.
- **Improved exhaust temperature monitoring and control:**
Advanced statistical algorithms detect turbine hot/cold spots and automatically reject failed thermocouples.
- **Fail-safe features:**
Redundant overspeeds; open/short monitoring of mA and thermocouples; readback monitoring of outputs, and special self-check features improve safety and reliability.
- **Non-proprietary interfaces:**
Simple 4-20 mA, RTD, thermocouple, and dry contact I/O allows simple interface to existing sequence/protection logic unit, making low-cost partial upgrades practical, and system troubleshooting simple.
- **Improved operator information with optional HMI:**
Optional Human-Machine Interface MS Windows-based graphic operator interface displays system status, trending and data logging, which can be used as part of a preventive maintenance program.

SCOPE OF SUPPLY

The application control package for GE Frame 3® gas turbine compressor drive system, includes:

Analog inputs, 4-20 mA:

- Load setpoint (capacity control)
- Compressor discharge pressure (PCD)
- Fuel interstage pressure (fuel)

Analog inputs, frequency:

- Three (3) redundant NHP
- Three (3) redundant NLP
- One (1) starter speed

Analog inputs, mV:

- EGT (up to 18 thermocouples)

Analog outputs, 4-20 mA:

- Speed ratio valve position demand
- Fuel control valve position demand
- Nozzle position setpoint

Operating states:

- Firing
- Warm-up
- Accelerate
- Load
- Synchronize

Status, alarms, and shutdowns:

- Fault
- NHP overspeed alarm
- NHP underspeed alarm
- NHP overspeed shutdown
- Redundant NHP overspeed shutdown
- ΔNHP alarm
- NLP overspeed alarm
- NLP underspeed alarm
- NLP overspeed shutdown
- Redundant NLP overspeed shutdown
- ΔNLP alarm
- High EGT alarm
- High EGT shutdown
- Low EGT shutdown
- Rejected thermocouple
- Too few thermocouples shutdown
- Thermocouple spread alarm
- Thermocouple spread shutdown
- NLP breakaway
- Bolt test
- Manual
- Starter overspeed
- High firing fuel pressure shutdown
- PCD bias active
- Transmitter failure alarms
- Transmitter failure shutdowns
- Output failure shutdowns
- Control mode



SCOPE OF SUPPLY - Continued

Controllers/special features:

- NHP controller for fuel valve
- NHP acceleration controller for fuel valve
- NLP controller for fuel valve
- NLP acceleration controller for fuel valve
- EGT controller for fuel valve
- EGT rate of rise controller for fuel valve
- NHP controller for nozzles
- EGT controller for nozzles
- Combustion monitoring system

Ramps:

- Firing (lean lightoff) ramp
- Start-up ramp
- Loading ramp
- NLP cooldown ramp

OPTIONS FOR COMPLETE CONTROL SYSTEM UPGRADE

- Gas turbine sequencing and protection discrete logic
- Generator sequencing and protection discrete logic
- Communication interface to DCS or SCADA
- Human machine interface unit with licensed software package
- Complete custom engineered control panel, factory tested and ready to install
- Fuel valve system upgrade
- Nozzle actuator system upgrade or retrofit
- Thermocouple upgrade
- Flame sensor upgrade
- Vibration system upgrade
- Installation and commissioning
- Training

###

GE Frame 3®, Allen-Bradley, General Electric (GE), Modicon and Siemens are registered trademarks of their respective owners.

Petrotech, Inc.
 151 Brookhollow Esplanade
 New Orleans, Louisiana 70123
 USA

Phone: (504) 620-6600
 Fax: (504) 620-6601
 Email: info@petrotechinc.com
 Website: www.petrotechinc.com