

# ALLISON® 501-KB GAS TURBINE COMPRESSOR DRIVE APPLICATION CONTROL PACKAGE

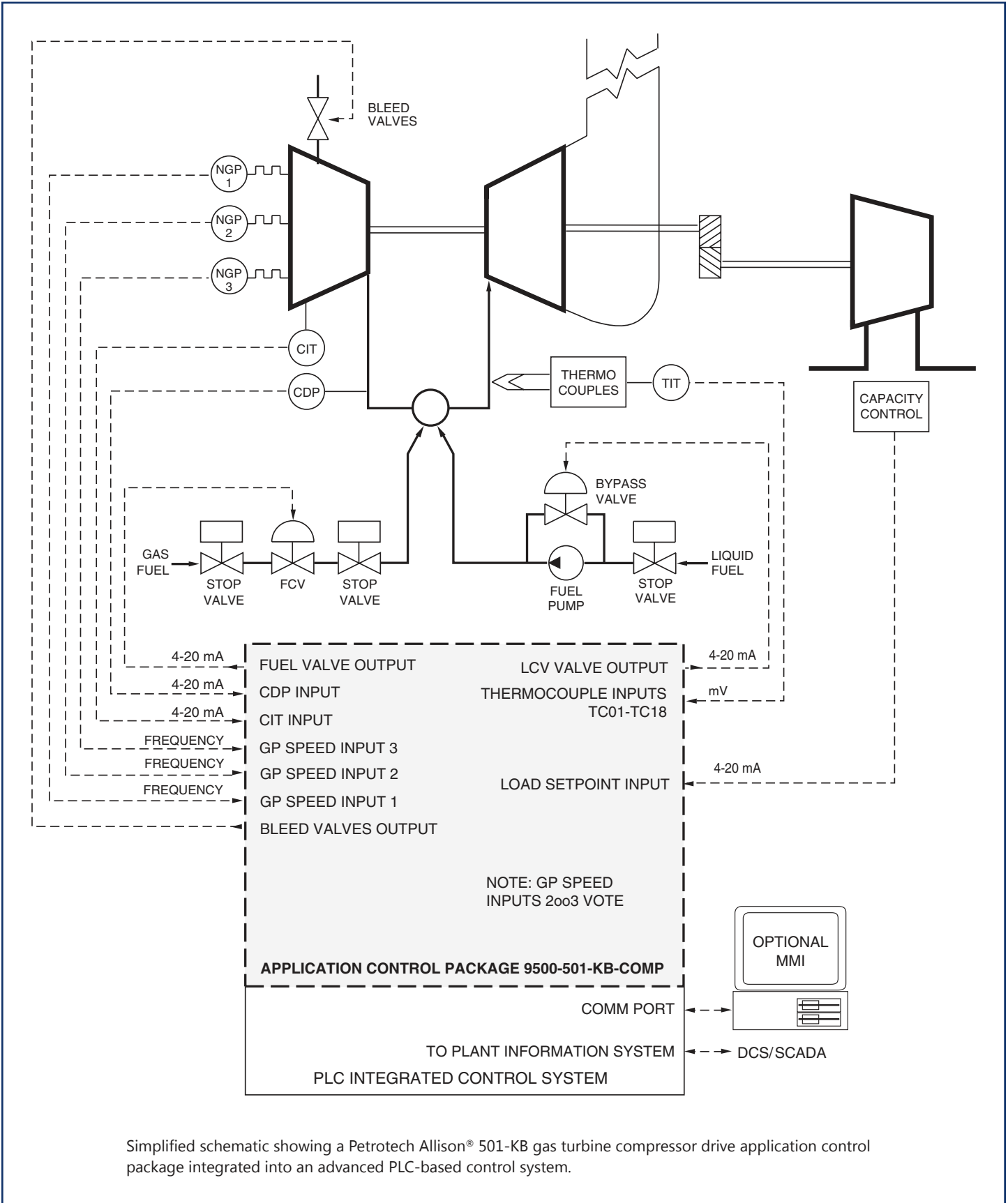

MAY 2012



Simplified schematic showing a Petrotech Allison® 501-KB gas turbine compressor drive application control package integrated into an advanced PLC-based control system.



## APPLICATION

The Allison® 501-KB gas turbine compressor drive application control package replaces older mechanical/hydraulic/electronic/pneumatic fuel regulators with a modern, reliable application control package which runs on an advanced PLC-based system. The control package for the gas turbine provides fuel control and bleed valve control.

## ADVANTAGES

### • Hardware independent system:

Application control package's portability allows customer choice of platform, reducing need for additional spare parts and training expenses. Available PLCs include General Electric, Siemens/TI, Allen-Bradley, and Modicon.

### • Fault tolerant:

Control package is available on fault tolerant controllers for critical control applications.

### • Simplified interface to DCS or SCADA:

Communication tasks are handled with a separate, dedicated module in the PLC, increasing data rate and simplifying network installation.

### • Improved fuel regulation:

Fast loop sampling rate, combined with modern digital control techniques improve steady-state setpoint control, and reduce overshoot during transients.

### • Improved start-up reliability:

Special "lean lightoff" procedure ignites all combustors with essentially 100% reliability, and with greatly reduced thermal stress.

### • Improved engine temperature monitoring and control:

Advanced statistical algorithms detect turbine hot/cold spots and automatically reject failed thermocouples.

### • Fail-safe features:

Redundant overspeeds; open/short monitoring of mA and thermocouples; readback monitoring of outputs, and special self-check features improve safety.

### • Non-proprietary interfaces:

Simple 4- 20 mA, RTD, thermocouple, and dry contact I/O allow simple interface to existing sequence/protection logic unit, making low-cost partial upgrades practical, and system troubleshooting simple.

### • Improved operator information with optional MMI:

Optional Man-Machine Interface MS Windows-based graphic operator interface displays system status, trending and data logging, which can be used as part of a preventative maintenance program.

## SCOPE OF SUPPLY

The application control package for the Allison 501-KB gas turbine compressor drive application control package, includes:

### Analog inputs, 4-20 mA:

- Watts (load control).
- Compressor discharge pressure (CDP).
- Ambient temperature (CIT).

### Analog inputs, frequency:

- Three (3) redundant NGP.

### Analog inputs, mV:

- TIT (up to 18 thermocouples).

### Analog outputs, 4-20 mA:

- Fuel control valve position setpoint.
- Bleed valve position setpoint.

### Operating states:

- Firing.
- Warm-up.
- Accelerate.
- Load.

### Status, alarms, and shutdowns:

- Fault.
- GP overspeed alarm.
- GP underspeed shutdown.
- GP overspeed shutdown.
- Redundant GP overspeed shutdown.
- $\Delta$ GP alarm
- High TIT alarm.
- High TIT shutdown.
- Low TIT shutdown.
- Low TIT delayed alarm.
- Rejected thermocouple.
- Too few thermocouples shutdown.
- $\Delta$ T alarm
- $\Delta$ T shutdown
- Thermocouple spread alarm.
- Thermocouple spread shutdown.
- Turbine maximum limit.
- Turbine minimum limit.
- GP speed #1.
- GP speed #2.
- GP speed #3.
- GP speed #4.
- GP speed #5.
- TIT switch #1.
- Manual.
- High firing fuel pressure shutdown.
- Transmitter failure alarms.
- Transmitter failure shutdowns.
- Output failure shutdowns.
- Control mode.

### Controllers/special features:

- Start-up controller for fuel valve.
- NGP controller for fuel valve.
- TIT controller for fuel valve.
- TIT rate of rise controller.
- Fuel acceleration schedule.
- Fuel deceleration schedule.
- Deceleration rate limiter.
- Corrected speed (CNGP) override.
- Bleed valve controller.
- Combustion monitoring system.
- Stagnation detection system.



**Ramps:**

- Firing (lean lightoff) ramp.
- Start-up ramp.
- Loading ramp.
- Cooldown ramp.

**Does not include:**

- PLC hardware.
- Compressor application control package.
- Gas turbine sequencing and protection discrete logic.
- Compressor sequencing and protection discrete logic.
- End elements.

**OPTIONS FOR COMPLETE CONTROL SYSTEM UPGRADE**

---

- Gas turbine sequencing and protection discrete logic.
- Compressor sequencing and protection discrete logic.
- Communication interface to DCS or SCADA.
- PLC hardware.
- Man machine interface unit with WonderWare InTouch® licensed software package.
- Complete custom engineered control panel, factory tested and ready to install.
- Fuel control valve system upgrade.
- Bleed valve actuator system upgrade.
- Thermocouple upgrade.
- Synchronizing and regulation equipment.
- Vibration system upgrade.
- Installation and commissioning.
- Training

Petrotech, Inc.  
 151 Brookhollow Esplanade  
 New Orleans, Louisiana 70123  
 USA

Phone: (504) 620-6600  
 Fax: (504) 620-6601  
 Email: info@petrotechinc.com  
 Website: www.petrotechinc.com