

# GE FRAME 3® GAS TURBINE COMPRESSOR DRIVE APPLICATION CONTROL PACKAGE

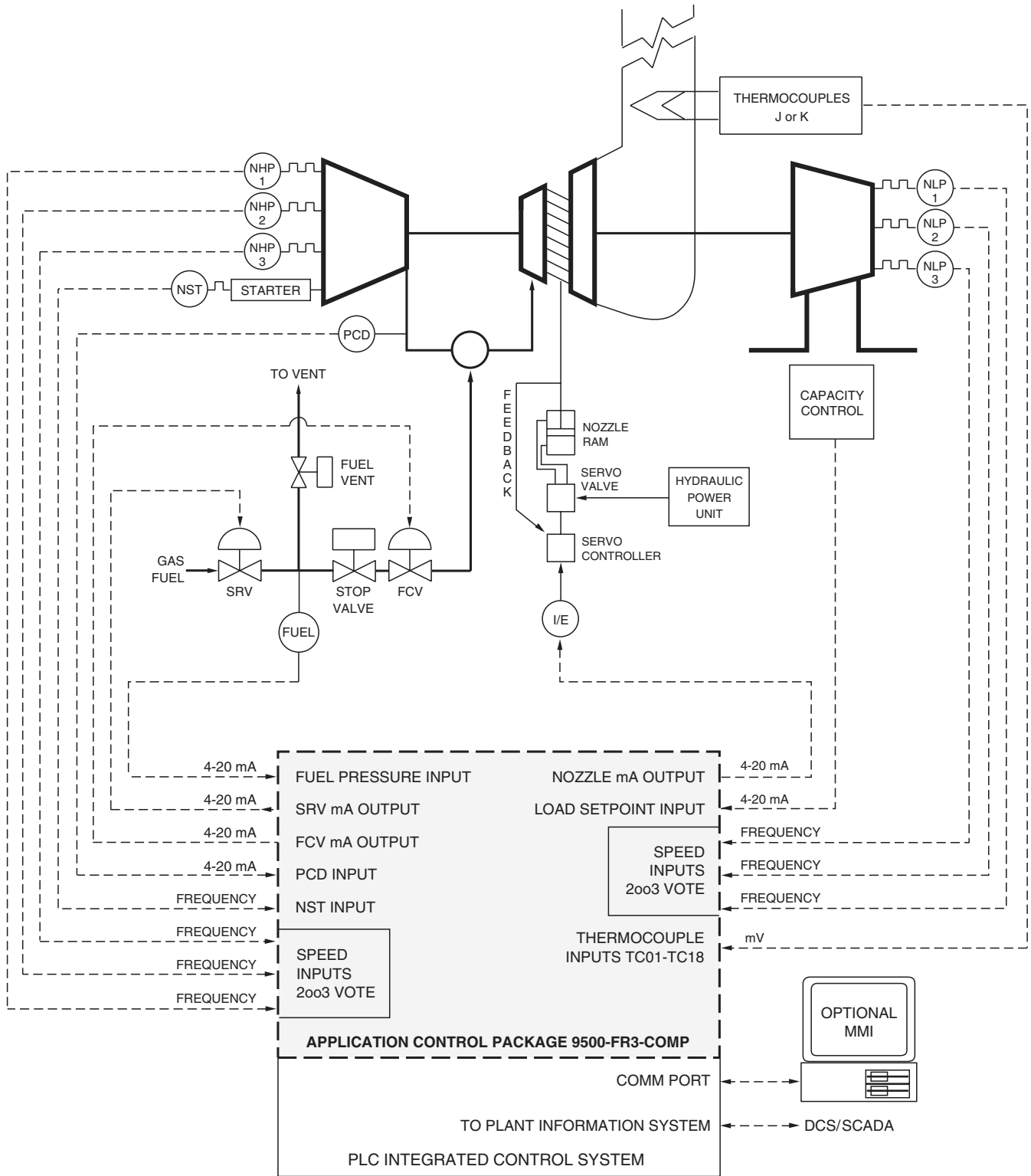

MAY 2012



Simplified schematic showing a Petrotech GE Frame 3® gas turbine compressor drive application control package integrated into an advanced PLC-based control system.



## APPLICATION

The GE Frame 3® application control package replaces older mechanical/hydraulic/electronic/pneumatic Frame 3 fuel regulators with a modern, reliable application control package which runs on an advanced PLC-based system. The control package for the gas turbine provides fuel control, speed ratio control, and nozzle control based on speed and temperature.

## ADVANTAGES

### • **Hardware independent system:**

Application control package's portability allows customer choice of PLC platform, reducing need for additional spare parts and training expenses. Available PLCs include General Electric, Siemens/TI, Allen-Bradley, and Modicon.

### • **Fault tolerant:**

The control package is available on tolerant controllers for critical control applications.

### • **Simplified interface to DCS or SCADA:**

Communication tasks are handled with a separate, dedicated module in the PLC, increasing data rate and simplifying network installation.

### • **Improved fuel regulation:**

Fast loop sampling rate, combined with modern digital control techniques, improves steady-state setpoint control, and reduces overshoot during transients.

### • **Improved start-up reliability:**

Special "lean lightoff" procedure ignites all burners with essentially 100% reliability, and with greatly reduced thermal stress.

### • **Improved exhaust temperature monitoring and control:**

Advanced statistical algorithms detect turbine hot/cold spots and automatically reject failed thermocouples.

### • **Fail-safe features:**

Redundant overspeeds; open/short monitoring of mA and thermocouples; readback monitoring of outputs, and special self-check features improve safety.

### • **Non-proprietary interfaces:**

Simple 4-20 mA, RTD, thermocouple, and dry contact I/O

allows simple interface to existing sequence/protection logic unit, making low-cost partial upgrades practical, and system troubleshooting simple.

### • **Improved operator information with optional MMI:**

Optional Man-Machine Interface MS Windows-based graphic operator interface displays system status, trending and data logging, which can be used as part of a preventive maintenance program.

## SCOPE OF SUPPLY

The application control package for Frame 3 gas turbine compressor drive system, includes:

### **Analog inputs, 4-20 mA:**

- Load setpoint (capacity control).
- Compressor discharge pressure (PCD).
- Fuel interstage pressure.

### **Analog inputs, frequency:**

- Three (3) redundant NHP.
- Three (3) redundant NLP.
- One (1) starter speed.

### **Analog inputs, mV:**

- EGT (up to 18 thermocouples).

### **Analog outputs, 4-20 mA:**

- Speed ratio valve position setpoint.
- Fuel control valve position setpoint.
- Nozzle position setpoint.

### **Operating states:**

- Firing.
- Warm-up.
- Accelerate.
- Load.
- Upset.

### **Status, alarms, and shutdowns:**

- Fault.
- NHP overspeed alarm.
- NHP underspeed alarm.
- NHP overspeed shutdown.
- Redundant NHP overspeed shutdown.
- $\Delta$ NHP alarm.
- NLP overspeed alarm.
- NLP underspeed alarm.
- NLP overspeed shutdown.
- Redundant NLP overspeed shutdown.
- $\Delta$ NLP alarm.
- High EGT alarm.
- High EGT shutdown.
- Low EGT shutdown.
- Rejected thermocouple.
- Too few thermocouples shutdown.
- $\Delta$ T alarm.
- $\Delta$ T shutdown.
- Thermocouple spread alarm.
- Thermocouple spread shutdown.
- Turbine maximum limit.
- Turbine minimum limit.
- NHP speed #1.
- NHP speed #2.
- NHP speed #3.
- NHP speed #4.
- NHP speed #5.
- NLP breakaway.
- EGT switch #1.
- Bolt test.
- Manual.
- NLP speed #1.
- NLP speed #2.
- Starter overspeed.
- Starter zero speed.
- High firing fuel pressure shutdown.
- PCD bias active.
- Transmitter failure alarms.
- Transmitter failure shutdowns.
- Output failure shutdowns.
- Control mode.



**Controllers/special features:**

- NHP controller for fuel valve.
- NHP acceleration controller for fuel valve.
- NLP controller for fuel valve.
- NLP acceleration controller for fuel valve.
- EGT controller for fuel valve.
- EGT rate of rise controller for fuel valve.
- NHP controller for nozzles.
- EGT controller for nozzles.
- Combustion monitoring system.

**Ramps:**

- Firing (lean lightoff) ramp.
- Start-up ramp.
- Loading ramp.
- NLP cooldown ramp.

**Does not include:**

- PLC hardware.
- Compressor application control package.
- Gas turbine sequencing and protection discrete logic.
- Compressor sequencing and protection discrete logic.

**OPTIONS FOR COMPLETE CONTROL SYSTEM UPGRADE**

- Compressor application control package.
- Gas turbine sequencing and protection discrete logic.
- Compressor sequencing and protection discrete logic.
- Communication interface to DCS or SCADA.
- Capacity control application control package.
- PLC hardware.
- Man machine interface unit with Wonderware InTouch® licensed software package.
- Complete custom engineered control panel, factory tested and ready to install.
- Fuel valve system upgrade.
- Nozzle actuator system upgrade or retrofit.
- Thermocouple upgrade.
- Flame sensor upgrade.
- Vibration system upgrade.
- Installation and commissioning.
- Training

Petrotech, Inc.  
 151 Brookhollow Esplanade  
 New Orleans, Louisiana 70123  
 USA

Phone: (504) 620-6600  
 Fax: (504) 620-6601  
 Email: info@petrotechinc.com  
 Website: www.petrotechinc.com