

SOLAR CENTAUR® GAS TURBINE COMPRESSOR DRIVE APPLICATION CONTROL PACKAGE

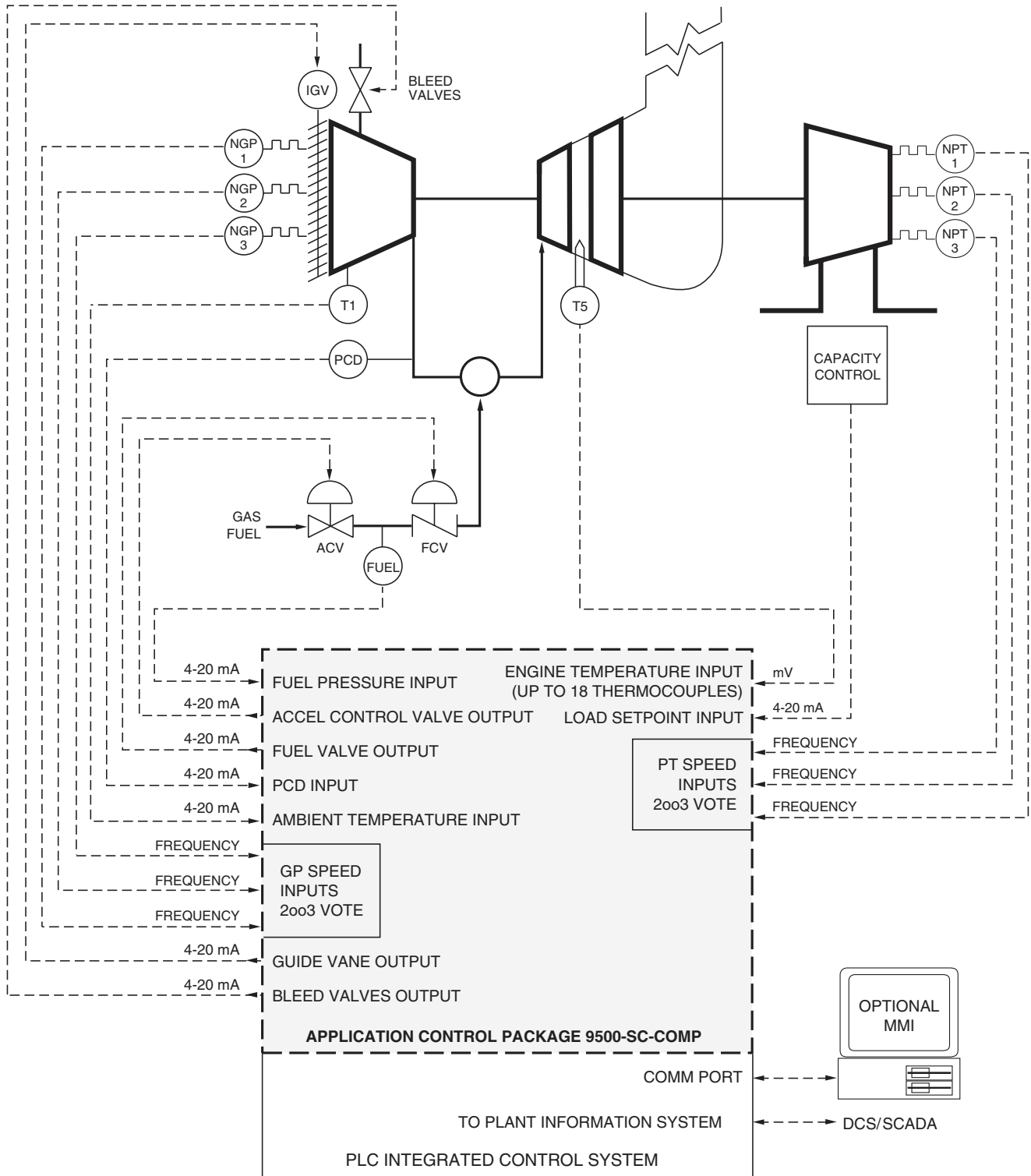

MAY 2012



Simplified schematic showing a Petrotech Solar Centaur® compressor drive application control package integrated into an advanced PLC-based control system.



APPLICATION

The Solar Centaur® application control package replaces older mechanical/hydraulic/electronic/pneumatic Centaur® fuel regulators with a modern, reliable application control package which runs on an advanced PLC-based system. The control package for the gas turbine provides fuel control, acceleration control, inlet guide vane control, and bleed valve control.

ADVANTAGES

• Hardware independent system:

Application control package's portability allows customer choice of PLC platform, reducing need for additional spare parts and training expenses. Available PLCs include General Electric, Siemens/TI, Allen-Bradley, and Modicon.

• Fault tolerant:

The control package is available on fault tolerant controllers for critical control applications.

• Simplified interface to DCS or SCADA:

Communication tasks are handled with a separate, dedicated module in the PLC, increasing data rate and simplifying network installation.

• Improved fuel regulation:

Fast loop sampling rate, combined with modern digital control techniques, improves steady-state setpoint control, and reduces overshoot during transients.

• Improved start-up reliability:

Special "lean lightoff" procedure ignites all combustors with essentially 100% reliability, and with greatly reduced thermal stress.

• Improved engine temperature monitoring and control:

Advanced statistical algorithms detect turbine hot/cold spots and automatically reject failed thermocouples.

• Fail-safe features:

Redundant overspeeds; open/short monitoring of mA and thermocouples; readback monitoring of outputs, and special self-check features improve safety.

• Non-proprietary interfaces:

Simple 4-20 mA, RTD, thermocouple, and dry contact I/O allow simple interface to existing sequence/protection logic unit, making low-cost partial upgrades practical, and system troubleshooting simple.

• Improved operator information with optional MMI:

Optional Man-Machine Interface MS Windows-based graphic operator interface displays system status, trending and data logging, which can be used as part of a preventive maintenance program.

• Reduced maintenance and calibration:

Acceleration control valve schedule is integrated into the application control package, increasing reliability while decreasing system complexity.

SCOPE OF SUPPLY

The application control package for Solar Centaur® gas turbine compressor drive system, includes

Analog inputs, 4-20 mA:

- Load setpoint (capacity control).
- Compressor discharge pressure (PCD).
- Fuel interstage pressure.
- Ambient temperature.

Analog inputs, frequency:

- Three (3) redundant NGP.
- Three (3) redundant NPT).

Analog inputs, mV:

- T5 (up to 18 thermocouples).

Analog outputs, 4-20 mA:

- Acceleration control valve position setpoint.
- Fuel control valve position setpoint.
- Inlet guide vanes position setpoint (if applicable).
- Bleed valve position setpoint.

Operating states:

- Firing.
- Warm-up.
- Accelerate.
- Load.

Status, alarms, and shutdowns:

- Fault .
- GP overspeed alarm.
- GP underspeed shutdown.
- GP overspeed shutdown.
- Redundant GP overspeed shutdown.
- Δ GP alarm.
- NPT overspeed alarm.
- NPT underspeed shutdown.
- NPT overspeed shutdown.
- Redundant NPT overspeed shutdown.
- Δ NTP alarm.
- High T5 alarm.
- High T5 shutdown.
- Low T5 shutdown.
- Low T5 delayed alarm.
- High T5 delayed shutdown.
- Rejected thermocouple.
- Too few thermocouples shutdown
- Δ T alarm.
- Δ T shutdown.
- Thermocouple spread alarm.
- Thermocouple spread shutdown.
- Turbine maximum limit.
- Turbine minimum limit.
- GP speed #1.
- GP speed #2.
- GP speed #3.
- GP speed #4.
- GP speed #5.
- NPT speed #1.
- NPT speed #2.
- T5 switch #1.
- Manual.
- High firing fuel pressure shutdown.
- Transmitter failure alarms.
- Transmitter failure shutdowns.
- Output failure shutdowns.
- Control mode.



Controllers/special features:

- Start-up controller for fuel valve.
- GP controller for fuel valve.
- NPT controller for fuel valve.
- T5 controller for fuel valve.
- Inlet guide vane controller.
- Bleed valve controller.
- Acceleration control.
- Combustion monitoring system.

Ramps:

- Firing (lean lightoff) ramp.
- Start-up ramp.
- Loading ramp.
- Cooldown ramp

Does not include:

- PLC hardware.
- Compressor application control package.
- Gas turbine sequencing and protection discrete logic.
- Compressor sequencing and protection discrete logic.
- End elements.

OPTIONS FOR COMPLETE CONTROL SYSTEM UPGRADE

- Compressor application control package.
- Gas turbine sequencing and protection discrete logic.
- Compressor sequencing and protection discrete logic.
- Communication interface to DCS or SCADA.
- Capacity control application control package.
- PLC hardware.
- Man machine interface unit with WonderWare InTouch® licensed software package.
- Complete custom engineered control panel, factory tested and ready to install.
- Fuel control valve system upgrade.
- Acceleration control valve system upgrade.
- Inlet guide vanes actuator system upgrade or retrofit.
- Bleed valve actuator system upgrade.
- Thermocouple upgrade.
- Vibration system upgrade.
- Installation and commissioning.
- Training

Petrotech, Inc.
 151 Brookhollow Esplanade
 New Orleans, Louisiana 70123
 USA

Phone: (504) 620-6600
 Fax: (504) 620-6601
 Email: info@petrotechinc.com
 Website: www.petrotechinc.com