

# SOLAR CENTAUR® GAS TURBINE PUMP DRIVE APPLICATION CONTROL PACKAGE

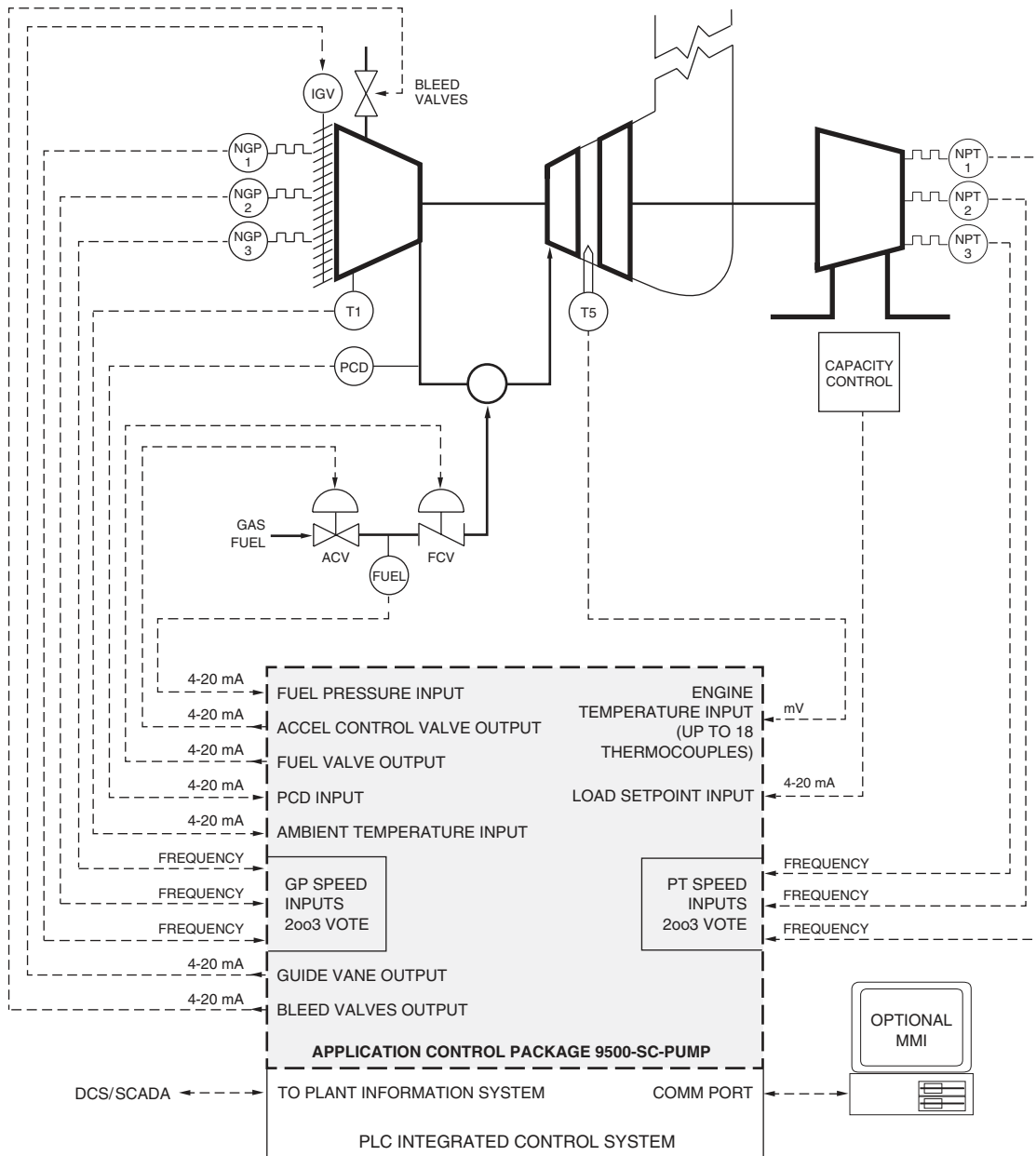

MAY 2012



Simplified schematic showing a Petrotech Solar Centaur® pump drive application control package integrated into an advanced PLC-based control system.



## APPLICATION

The Solar Centaur® application control package replaces older mechanical/hydraulic/electronic/pneumatic Centaur® fuel regulators with a modern, reliable application control package which runs on an advanced PLC-based system. The control package for the gas turbine provides fuel control, acceleration control, inlet guide vane control, and bleed valve control.

## ADVANTAGES

### • Hardware independent system:

Application control package's portability allows customer choice of PLC platform, reducing need for additional spare parts and training expenses. Available PLCs include General Electric, Siemens/TI, Allen-Bradley, and Modicon.

### • Fault tolerant:

Control package is available on fault tolerant controllers for critical control applications.

### • Simplified interface to DCS or SCADA:

Communication tasks are handled with a separate, dedicated module in the PLC, increasing data rate and simplifying network installation.

### • Improved fuel regulation:

Fast loop sampling rate, combined with modern digital control techniques, improves steady-state setpoint control, and reduces overshoot during transients

### • Improved start-up reliability:

Special "lean lightoff" procedure ignites all combustors with essentially 100% reliability, and with greatly reduced thermal stress.

### • Improved exhaust temperature monitoring and control:

Advanced statistical algorithms detect turbine hot/cold spots and automatically reject failed thermocouples.

### • Fail-safe features:

Redundant overspeeds; open/short monitoring of mA and thermocouples; readback monitoring of outputs, and special self-check features improve safety.

### • Non-proprietary interfaces:

Simple 4-20 mA, RTD, thermocouple, and dry contact I/O allow simple interface to existing sequence/protection logic unit, making low-cost partial upgrades practical, and system troubleshooting simple.

### • Improved operator information with optional MMI:

Optional Man-Machine Interface MS Windows-based graphic operator interface displays system status, trending and data logging, which can be used as part of a preventive maintenance program.

### • Reduced maintenance and calibration:

Acceleration control valve schedule is integrated into the application control package, increasing reliability while decreasing system complexity.

## SCOPE OF SUPPLY

The application control package for Solar Centaur® gas turbine pump drive system, includes:

### Analog inputs, 4-20 mA:

- Load setpoint (capacity control)
- Compressor discharge pressure (PCD)
- Fuel interstage pressure
- Ambient temperature

### Analog inputs, frequency:

- Three (3) redundant NGP.
- Three (3) redundant NPT

### Analog inputs, mV:

- T5 (up to 18 thermocouples)

### Analog outputs, 4-20 mA:

- Acceleration control valve position setpoint
- Fuel control valve position setpoint
- Inlet guide vanes position setpoint (if applicable)
- Bleed valve position setpoint

### Operating states:

- Firing
- Warm-up
- Accelerate
- Load

### Status, alarms, and shutdowns:

- Fault
- GP overspeed alarm
- GP underspeed alarm
- GP overspeed shutdown
- Redundant GP overspeed shutdown
- ΔGP alarm
- NPT overspeed alarm
- NPT underspeed alarm
- NPT overspeed shutdown
- Redundant NPT overspeed shutdown
- ΔNPT alarm
- High T5 alarm.
- Low T5 shutdown
- Low T5 delayed alarm
- High T5 delayed shutdown
- Rejected thermocouple
- Too few thermocouples shutdown
- ΔT alarm
- ΔT shutdown
- Thermocouple spread alarm
- Thermocouple spread shutdown
- Turbine maximum limit
- Turbine minimum limit
- GP speed #1
- GP speed #2
- GP speed #3
- GP speed #4
- GP speed #5



**SCOPE OF SUPPLY - Continued**

- NPT speed #1
- NPT speed #2
- T5 switch #1
- Manual
- High firing fuel pressure shutdown
- Transmitter failure alarms
- Transmitter failure shutdowns
- Output failure shutdowns
- Control mode

**Controllers/special features:**

- Start-up controller for fuel valve
- GP controller for fuel valve
- NPT controller for fuel valve
- T5 controller for fuel valve
- Inlet guide vane controller
- Bleed valve controller
- Acceleration control
- Combustion monitoring system

**Ramps:**

- Firing (lean lightoff) ramp
- Start-up ramp
- Loading ramp
- Cooldown ramp

**Does not include:**

- PLC hardware
- Gas turbine sequencing and protection discrete logic
- Pump sequencing and protection discrete logic
- End elements

**OPTIONS FOR COMPLETE CONTROL SYSTEM UPGRADE**

- Gas turbine sequencing and protection discrete logic
- Pump sequencing and protection discrete logic
- Communication interface to DCS or SCADA
- Capacity control application control package
- PLC hardware
- Man machine interface unit with WonderWare InTouch® licensed software package
- Complete custom engineered control panel, factory tested and ready to install
- Fuel control valve system upgrade
- Acceleration control valve system upgrade
- Inlet guide vanes actuator system upgrade or retrofit
- Bleed valve actuator system upgrade
- Thermocouple upgrade
- Vibration system upgrade
- Installation and commissioning
- Training

Petrotech, Inc.  
 151 Brookhollow Esplanade  
 New Orleans, Louisiana 70123  
 USA

Phone: (504) 620-6600  
 Fax: (504) 620-6601  
 Email: info@petrotechinc.com  
 Website: www.petrotechinc.com